

DTS 5600 Series

The DTS 5600 series spindles feature units that highlight technologies from IE & E Industries, Inc and G II Solutions, Inc. IE & E has developed and successfully sold and supported spindles that are driven with hydraulic motors and that feature arbors that are removable between two centers. The removal method may be either actuated automatically through hydraulics and CNC control or with a manual valve. These units are useful when large diamond roll widths are required and/or diamond roll change is quite frequent. G II Solutions offers a drive package that allows the spindle to be driven by the same type of electric motors as used with all other G II Solutions' spindle models.

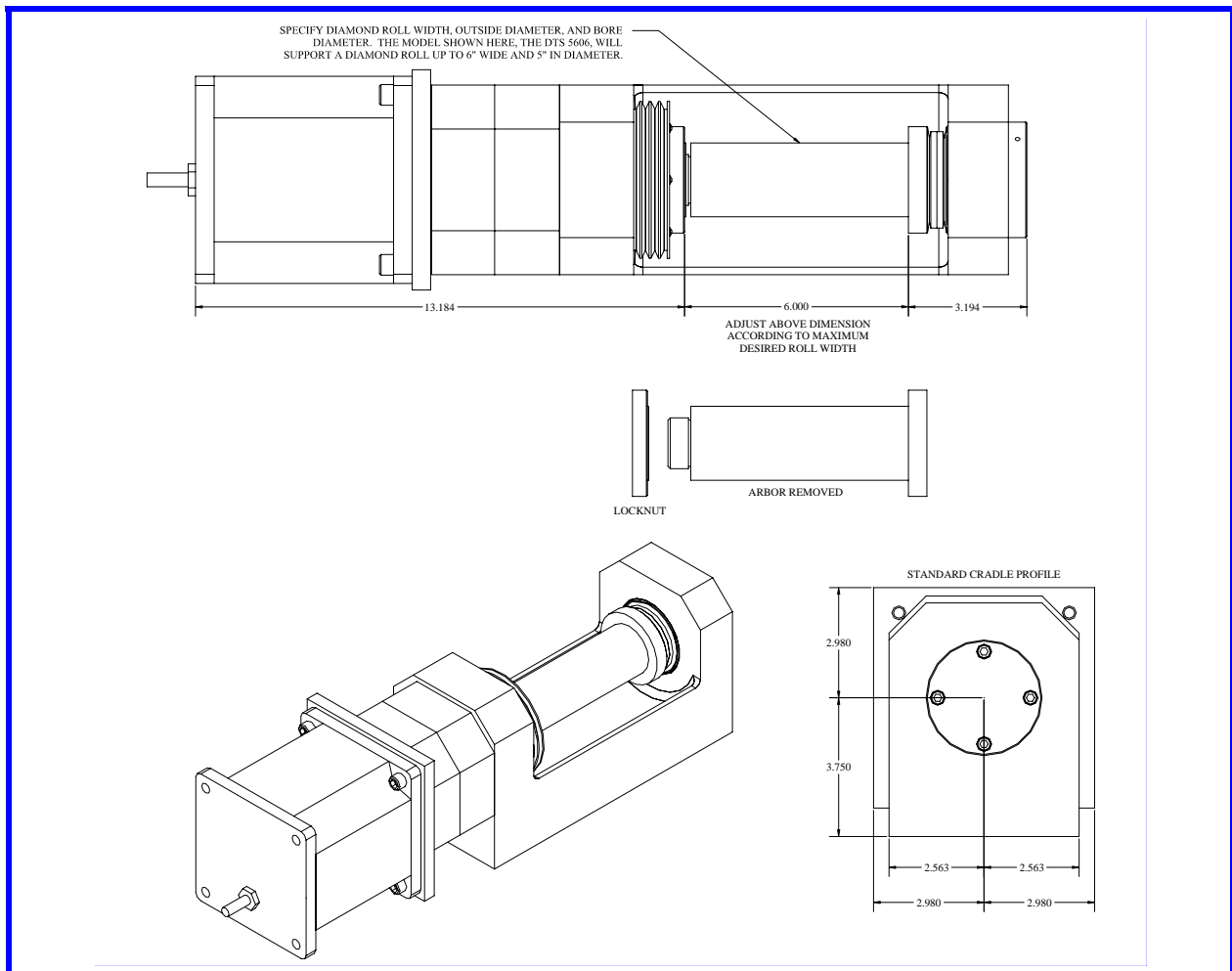

G II Solutions, Inc.
 201 Bank Street
 P.O. Box 428
 Central, SC 29630

Phone: 864.639.6605
 Fax: 864.639.4056
 E-mail: info@giisolutions.com
 Web Site: www.giisolutions.com