

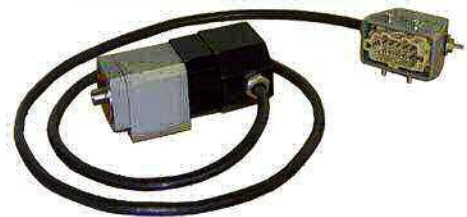

# G II SOLUTIONS, INC.

## DRESSING AND TRUING SYSTEMS

2023

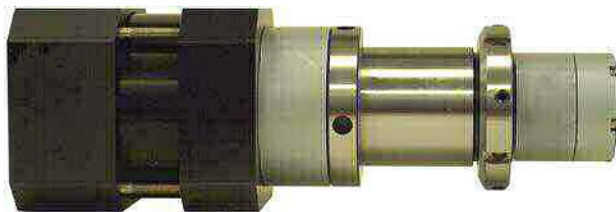

## DTS SPINDLES

*a complete line of electric spindles  
for dressing and truing  
grinding wheels*

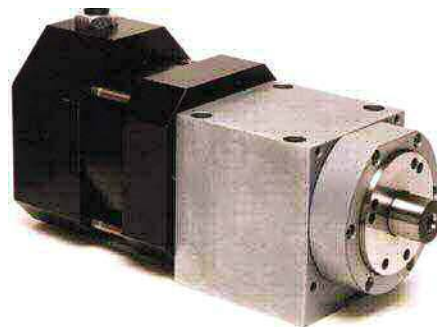
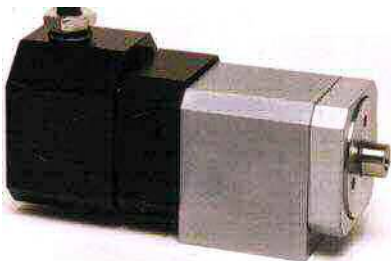

G II SOLUTIONS, INC.

201 BANK STREET \* P.O. BOX 428 \* CENTRAL, SC 29630-0428

PHONE: (864) 639-6605 \* FAX: (864) 639-4056

EMAIL: [INFO@GIISOLUTIONS.COM](mailto:INFO@GIISOLUTIONS.COM) \* WEB: [WWW.GIISOLUTIONS.COM](http://WWW.GIISOLUTIONS.COM)



## **G II Solutions, Inc.**

G II Solutions, Inc., established in 1983, began with a focus in the design and manufacture of custom automated machinery. Expertise was developed in CNC and PLC integration as well as the manufacture of quality mechanical hardware. These custom systems were successful.

One particular project, in 1987, required the development of a customized wheel dressing and truing system for a customer who could not locate any such system in the standard marketplace. Subsequent research and design led to the successful development of a stand-alone dressing machine which incorporated the use of an electric dressing and truing spindle maneuvered by a CNC controlled multi-axis precision table system. The success of this system, which is today still operational, followed by many years of development and improvement led to birth of a complete line of rotary dressing and truing devices, the DTS spindles.

G II Solutions, Inc. now focuses primarily on the development and manufacture of the DTS spindles and systems that control them. Many different models have been developed based on various consumer demands throughout the years. Continuous analysis and redesign, high quality control in manufacture, and years of experience in a new field keep G II Solutions, Inc. on the leading edge of electric, rotary dressing and truing technology.

G II Solutions, Inc. spindle systems are manufactured in the United States of America.



**G II Solutions, Inc.**  
201 Bank Street  
P.O. Box 428  
Central, SC 29630

Phone: 864.639.6605  
Fax: 864.639.4056  
E-mail: [info@giisolutions.com](mailto:info@giisolutions.com)  
Web Site: [www.giisolutions.com](http://www.giisolutions.com)

---

---

---

# Table of Contents

---

---

## ***DTS System Systems***

Overview	Page 4
Standard Configuration	Page 5

## ***Cantilever Mount Spindle Models***

DTS 1300	Page 6
DTS 1350	Page 7
DTS 1500	Page 8
DTS 3300 (formerly the DTS 2302)	Page 9

## ***Outboard Support Spindle Models***

DTS 3402 / DTS 3404	Page 10
Additional Products	Page 11

## ***Additional Spindle Information***

Spindle Cable Configurations / Air Purge Information	Page 12
--	---------

## ***Control Package***

Standard Configuration	Page 13
------------------------	---------

## ***DTS Spindle System Options***

Electrical Enclosure / Remote Pendant	Page 14
Miscellaneous Options	Page 15

## ***Additional Information***

Specification Work Sheet	Page 16
Specifying DTS Systems	Page 18
Observations & Precautions / Rotary Dressing & Truing Tips	Page 19



**G II Solutions, Inc.**  
201 Bank Street  
P.O. Box 428  
Central, SC 29630

Phone: 864.639.6605  
Fax: 864.639.4056  
E-mail: [info@giisolutions.com](mailto:info@giisolutions.com)  
Web Site: [www.giisolutions.com](http://www.giisolutions.com)

---

---

# Overview

---

Rigidity, precision, reliability, along with accurate and consistent speed control are essential in dressing and truing operations, especially those in which superabrasive grinding wheels are involved.

DTS spindle shafts are manufactured with A2 tool steel, hardened to 60-62 Rockwell. Shafts are supported by two duplex pairs of angular contact spindle bearings.

DTS spindles operate using custom-engineered brushless DC servomotors. The motors are mounted directly onto the spindle shaft generating the compactness that allows the spindles to fit on machines where many hydraulic and other electric spindles cannot fit. Despite the compactness of the DTS spindles, they maintain high power and a broad speed range.

DTS spindles operate under air purge. By maintaining positive pressure within the unit, DTS spindles are capable of withstanding the coolant-flooded environments associated with grinding machines.

DTS spindle control packages feature a servo amplifier that is powered from a 50-60 Hz, 90-270 Vac, single-phase power source. These servo amplifiers provide closed loop velocity control. Once spindle speed is selected, that speed is maintained, despite forces experienced when the spindle diamond roll is contacted with the grinding wheel.

Standard control packages are equipped with 1. a switch for controlling the spindle enable, 2. a switch for direction selection, 3. a potentiometer for adjusting speed, and 4. a digital display to monitor the spindle speed. Generally, these manual controls are used to establish the spindle's optimum speed and to set the appropriate direction. An interface module is included to provide a variety of inputs and outputs for control through PLC or CNC.

The above controlling components come preassembled and completely wired on an open panel. With this configuration, the control panel is intended to be mounted in the existing machine's enclosure. If there is no room in an existing enclosure, the controlling components may be provided in a Nema 12 enclosure that may be mounted to any vertical or horizontal surface. Manual controls and the speed display are relocated and mounted in the enclosure door.

Custom configurations and numerous options are available to accommodate various applications, customer requirements, and grinder types.



**GI Solutions, Inc.**  
201 Bank Street  
P.O. Box 428  
Central, SC 29630

Phone: 864.639.6605  
Fax: 864.639.4056  
E-mail: [info@gisolutions.com](mailto:info@gisolutions.com)  
Web Site: [www.gisolutions.com](http://www.gisolutions.com)

---

# Standard Configuration

Each DTS system includes 1. DTS spindle, 2. air purge unit, and 3. control package.

The standard spindle comes with up to 10 feet of spindle cable that terminates at the spindle electrical connector. This “standard spindle” is expected to be customized by the end user or by G II Solutions, Inc. to best fit the user requirements. Several brackets have already been developed to accommodate popular spindle/grinder combinations.

The air purge unit consists of an air shut-off valve, a filter/regulator combo, and a coalescing filter. Clean, dry, non-lubricated air is to be supplied to the air purge unit where it is regulated to 10-15 psi. Air exits the air purge unit and continues through nylon air tubing to quick connect fittings, which attach at the spindle electrical connector. Air continues in through the spindle cable, which contains an air tube inside, and into the spindle.

The standard control package is supplied with up to 10 feet of control panel cable that terminates at a bulkhead or surface mount connector. The connector attaches to the spindle electrical connector. Components that are included with the standard control package include a servo amplifier, manual controls, and an interface module that includes a variety of input and output options for CNC interface. The servo amplifier is to be powered by a 90 to 270 Vac, single source. Many options are available beyond the base system.

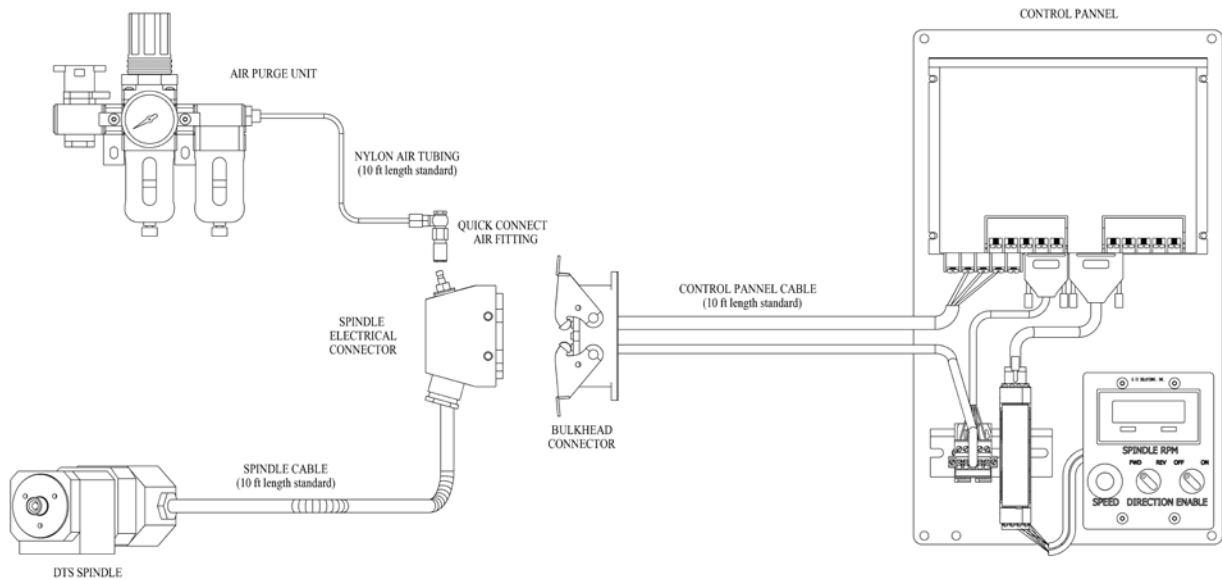

**G II Solutions, Inc.**  
 201 Bank Street  
 P.O. Box 428  
 Central, SC 29630

Phone: 864.639.6605  
 Fax: 864.639.4056  
 E-mail: [info@giisolutions.com](mailto:info@giisolutions.com)  
 Web Site: [www.giisolutions.com](http://www.giisolutions.com)

# DTS 1300

The DTS 1300 is the most compact of the DTS spindles and will fit on grinders with severe space constraints. The DTS 1300 is a cantilever mount spindle that is intended primarily for tracing forms into grinding wheels. Although compact, the DTS 1300 is still rigid and powerful enough to handle superabrasive applications. This model is intended to accommodate diamond rolls up to 4 inches (100 mm) in diameter and ½ inch (13 mm) wide.

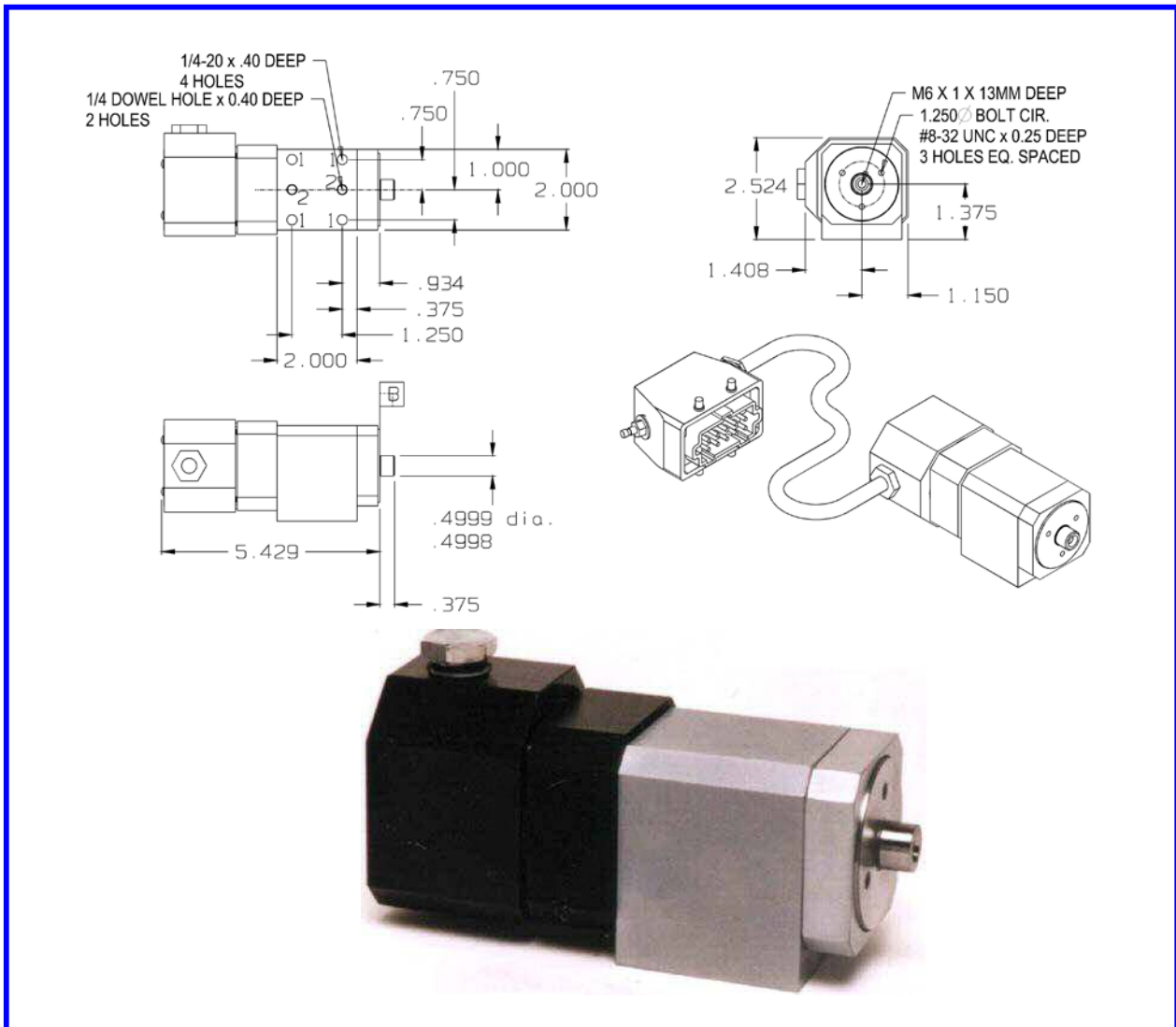

**G II Solutions, Inc.**  
 201 Bank Street  
 P.O. Box 428  
 Central, SC 29630

Phone: 864.639.6605  
 Fax: 864.639.4056  
 E-mail: [info@giisolutions.com](mailto:info@giisolutions.com)  
 Web Site: [www.giisolutions.com](http://www.giisolutions.com)

# DTS 1350

The DTS 1350 is based on the DTS 1300. It has a larger motor, but can still fit where there are severe space constraints. The DTS 1350 is a cantilever mount spindle that is intended primarily for tracing forms into grinding wheels. Although compact, the DTS 1350 is rigid and powerful enough to handle superabrasive applications. This model is intended to accommodate diamond rolls up to 4 inches (100 mm) in diameter and ½ inch (13 mm) wide.

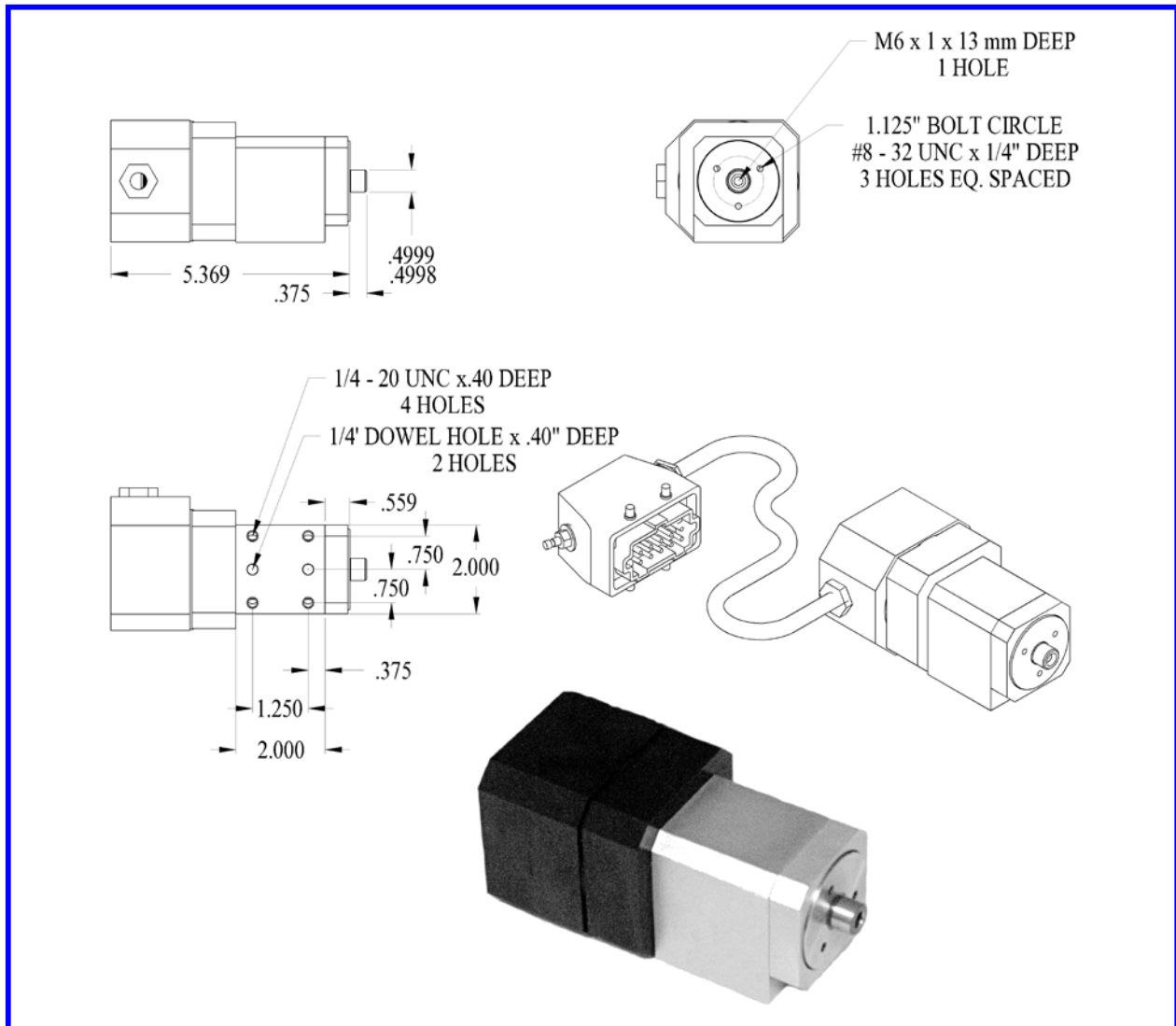

**G II Solutions, Inc.**  
 201 Bank Street  
 P.O. Box 428  
 Central, SC 29630

Phone: 864.639.6605  
 Fax: 864.639.4056  
 E-mail: [info@giisolutions.com](mailto:info@giisolutions.com)  
 Web Site: [www.giisolutions.com](http://www.giisolutions.com)

# DTS 1500

The DTS 1500 is a variation of the DTS 1350. The bearing housing is larger and has more mounting options. The DTS 1500 is a cantilever mount spindle that is intended primarily for tracing forms into grinding wheels. The DTS 1500 is compact, rigid and powerful enough to handle superabrasive applications. This model is intended to accommodate diamond rolls up to 4 inches (100 mm) in diameter and ½ inch (13 mm) wide.

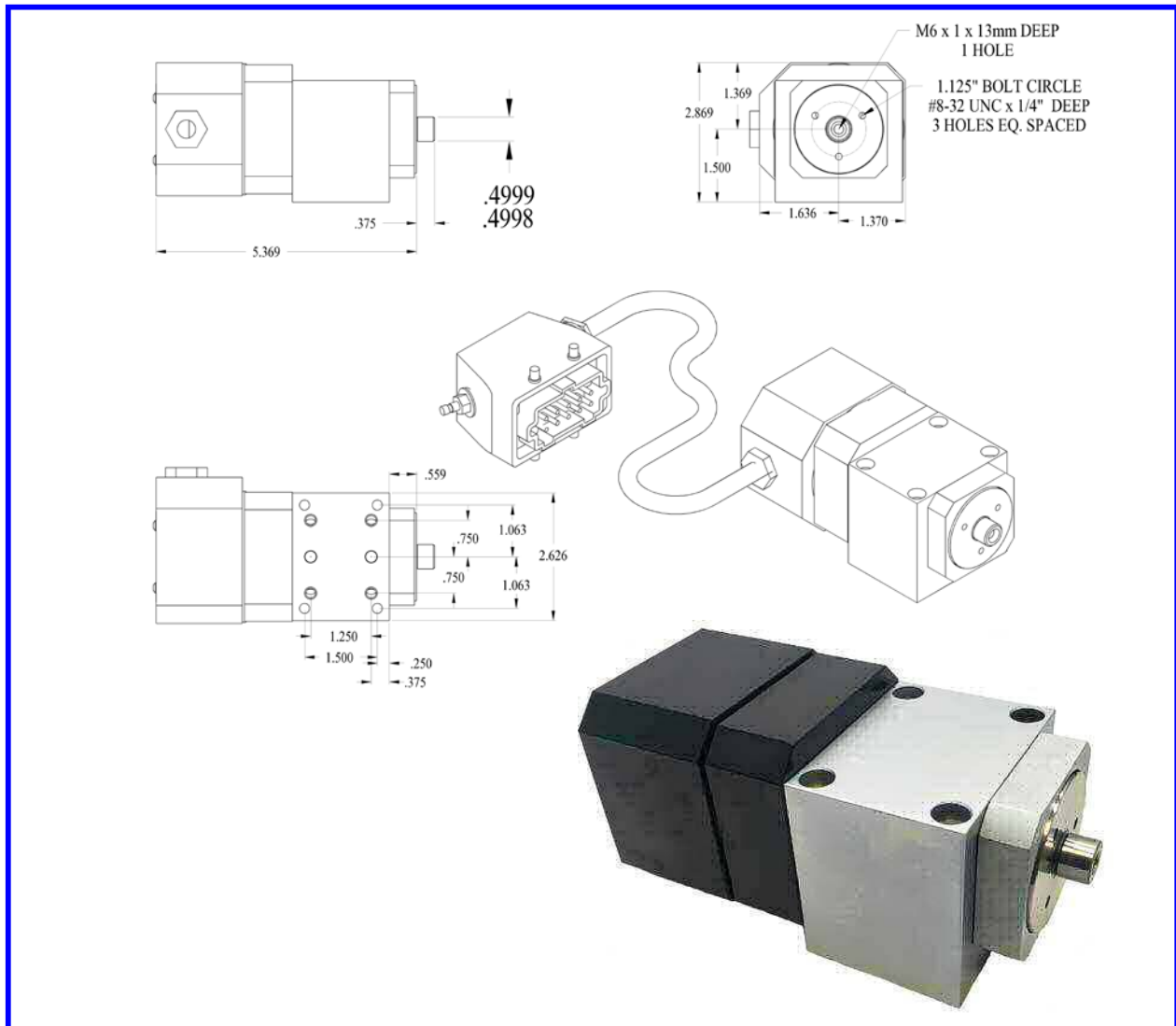

**G II Solutions, Inc.**  
 201 Bank Street  
 P.O. Box 428  
 Central, SC 29630

Phone: 864.639.6605  
 Fax: 864.639.4056  
 E-mail: [info@giisolutions.com](mailto:info@giisolutions.com)  
 Web Site: [www.giisolutions.com](http://www.giisolutions.com)



# DTS 3300 (direct replacement for DTS 2302)

The DTS 3300, a larger cantilever spindle, is also primarily intended for tracing forms into grinding wheels. When used in tracing applications, this model may accommodate diamond rolls up to 6 inches (150 mm) in diameter and ½ inch (13 mm) wide. Because the DTS 3300 features a larger shaft and bearings than the DTS 1300, it is sometimes used to plunge forms into grinding wheels, up to about 1½ inches (40 mm) wide.

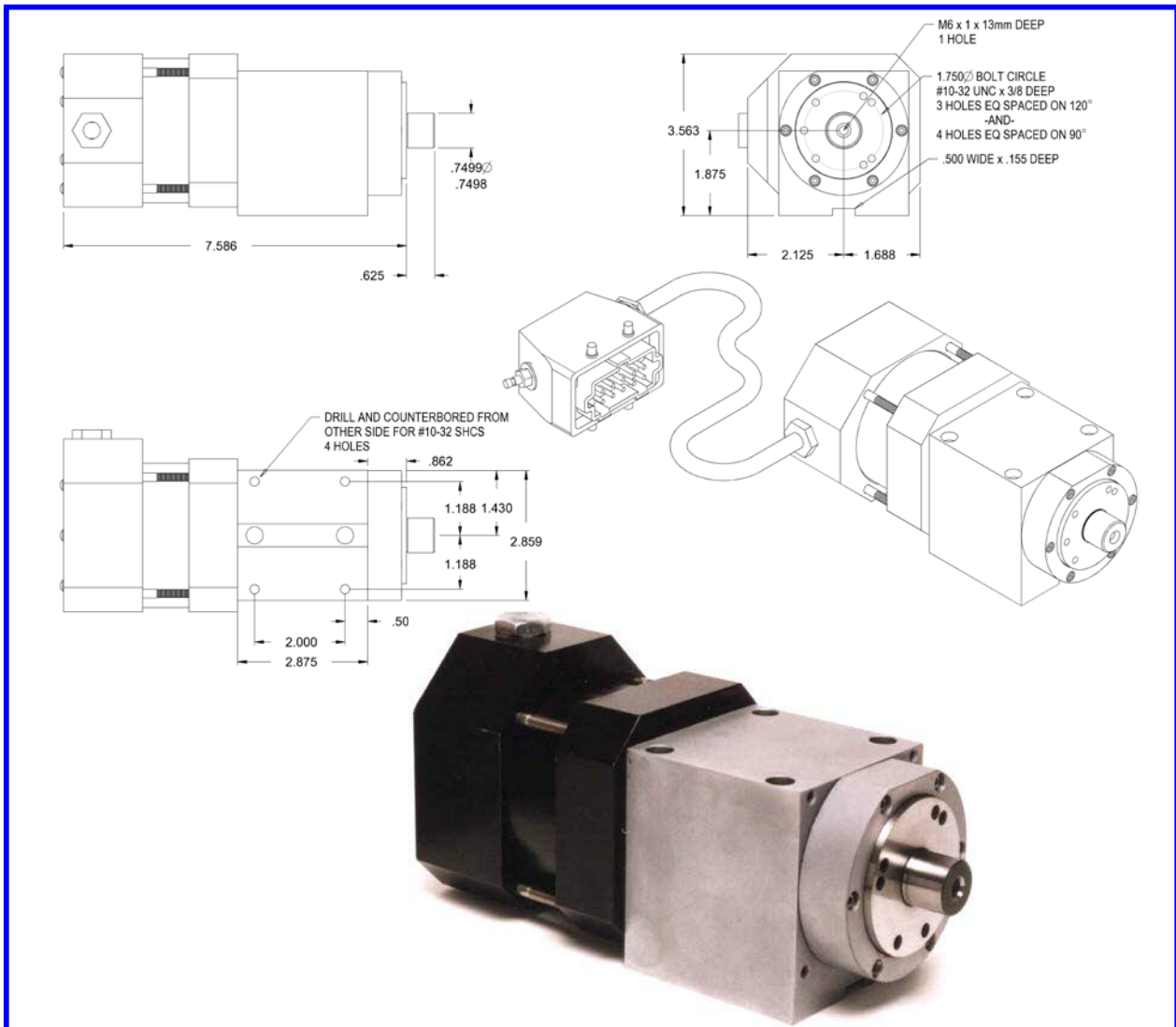

**G II Solutions, Inc.**  
 201 Bank Street  
 P.O. Box 428  
 Central, SC 29630

Phone: 864.639.6605  
 Fax: 864.639.4056  
 E-mail: [info@giisolutions.com](mailto:info@giisolutions.com)  
 Web Site: [www.giisolutions.com](http://www.giisolutions.com)

# DTS 3402 / DTS 3404

The DTS 3400 outboard support spindle series uses the same motor as the DTS 3300 cantilever mount spindle. These spindle models are useful when roll packs are required and in moderately demanding plunge applications. Each model requires a cradle to secure the spindle to the grinding machine. Please consult G II Solutions, Inc. for cradle information. The diamond rolls that each model may accommodate are listed in the table below.

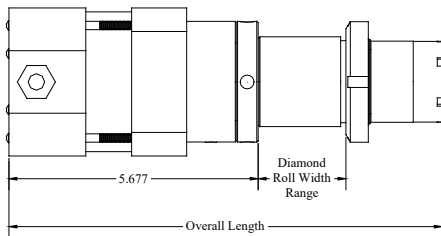

Spindle Model	Overall Length	Diamond Roll Width Range
DTS 3402	9.868	1.880 - 2.050
DTS 3404	11.868	3.880 - 4.050

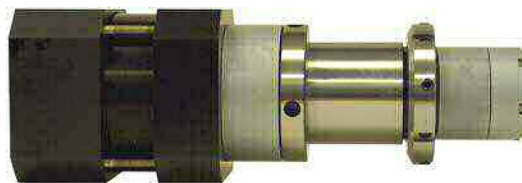
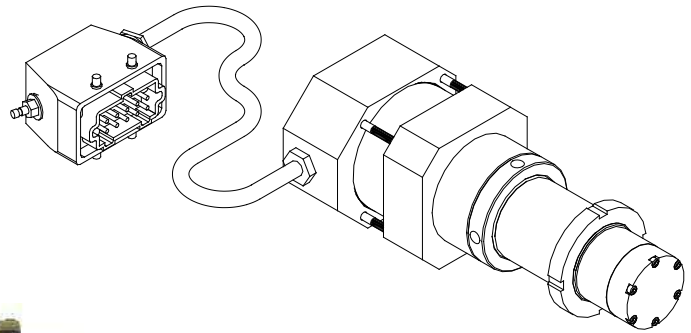
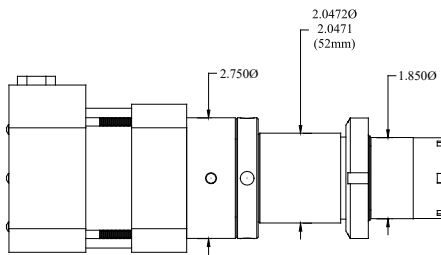
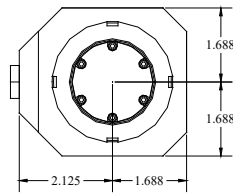

G II Solutions, Inc.  
201 Bank Street  
P.O. Box 428  
Central, SC 29630

Phone: 864.639.6605  
Fax: 864.639.4056  
E-mail: info@giisolutions.com  
Web Site: www.giisolutions.com

# Additional Products

In addition to the outboard support spindle models on the previous page, G II Solutions continues to support legacy models. Although these models are not actively promoted, G II Solutions maintains inventory to support these products. In some instances these models may be a better fit than current newer models. All outboard support spindle models require a “cradle” to properly support the unit. Each application invariably has different space constraints and diamond roll diameter requirements, so there are no “standard” cradles. Shown on this page are a few examples of cradles that have been used in previous applications.

## Legacy Models



DTS 1400



DTS 2400

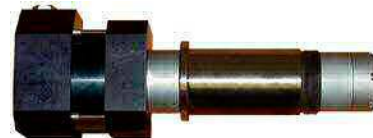

DTS 2500

## Cradle Examples

DTS 3404/4404 Low Profile Cradle



DTS 1400 in Compact Cradle



DTS 2400 Cradle

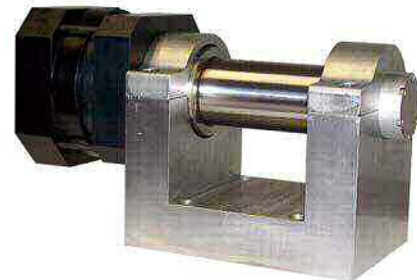

DTS 3404 in Heavy Duty Cradle for Large Diameter Diamond Roll



**G II Solutions, Inc.**  
201 Bank Street  
P.O. Box 428  
Central, SC 29630

Phone: 864.639.6605  
Fax: 864.639.4056  
E-mail: [info@giisolutions.com](mailto:info@giisolutions.com)  
Web Site: [www.giisolutions.com](http://www.giisolutions.com)

# Spindle Cable Configurations

Each spindle is configured according to customer specification for the cable to exit in one of four orientations: 3:00, 6:00, 9:00, or 12:00.

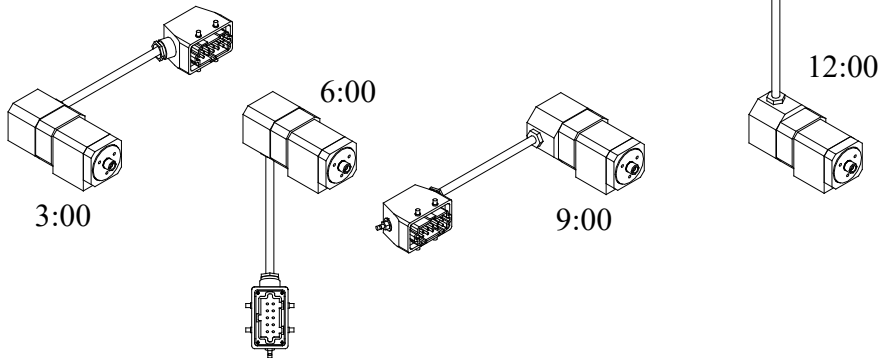

The cable may also exit directly through the rear of the spindle as an extra cost option.

REAR EXIT

# Air Purge Information

1. Factory air is supplied here through a 1/4 NPT female port.

2. Air is regulated to 15 psi and filtered with this air purge unit.

Air tube inside spindle cable

3. Airflow continues through nylon tubing and into the spindle electrical connector.

4. Air flow continues through the spindle cable, into the spindle near the motor, through the spindle bearings, and exits through the seal at the spindle face.



G II Solutions, Inc.  
201 Bank Street  
P.O. Box 428  
Central, SC 29630

Phone: 864.639.6605  
Fax: 864.639.4056  
E-mail: [info@giisolutions.com](mailto:info@giisolutions.com)  
Web Site: [www.giisolutions.com](http://www.giisolutions.com)

# Standard Configuration

The standard DTS system control package features an open panel with a set of pre-wired components. With this configuration, the control panel is intended to be mounted in the interfacing machine's existing electrical enclosure. Cable exits the control panel and terminates at a bulkhead connector that is generally mounted in the wall of the existing enclosure. The control package features a servo amplifier that requires a single or three phase, AC power source ranging from 90-270 volts. Also featured are a set of manual controls and an interface module for PLC or CNC interface. Additional configurations are available upon

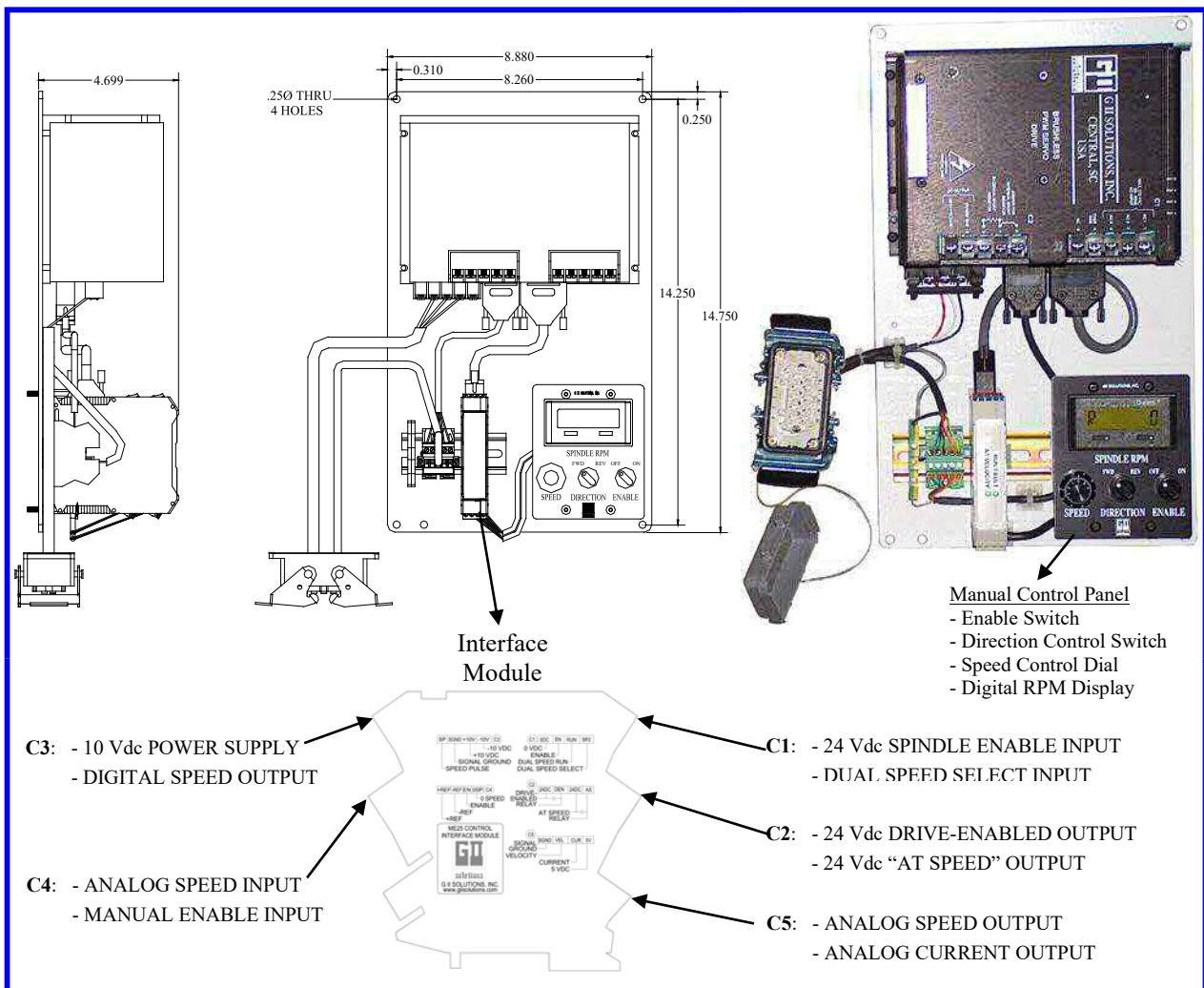

**G II Solutions, Inc.**  
201 Bank Street  
P.O. Box 428  
Central, SC 29630

Phone: 864.639.6605  
Fax: 864.639.4056  
E-mail: info@giisolutions.com  
Web Site: www.giisolutions.com

# Electrical Enclosure

With this option, the control panel is supplied in a Nema 12 enclosure. The enclosure has a hinged door and door clamps for easy access and operation. The manual controls and digital RPM display are relocated and installed in the door of the enclosure. The enclosure may be mounted to any horizontal or vertical surface using the external mounting feet provided.

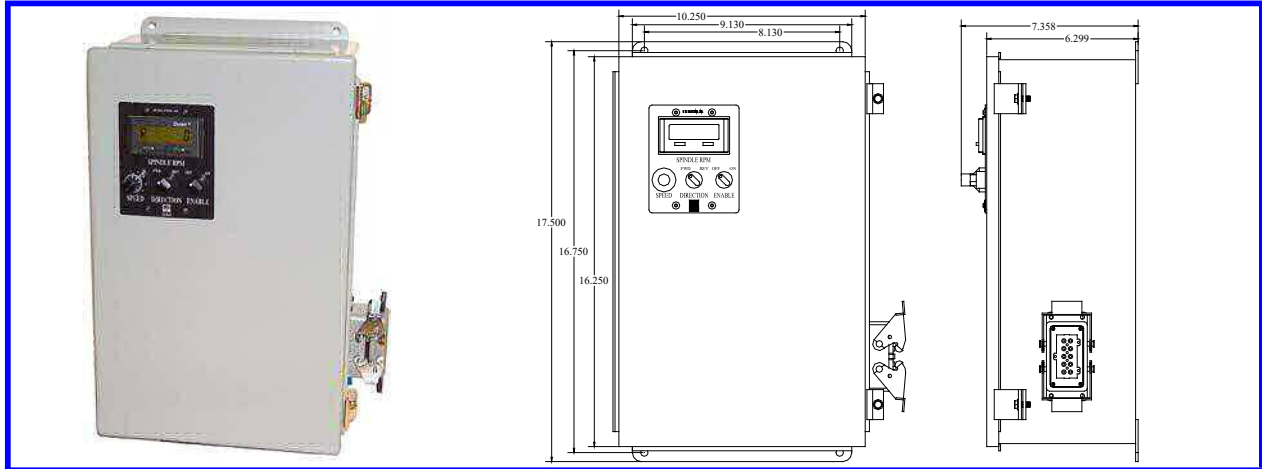

# Remote Pendant

This pendant offers manual control remote of the DTS central control system and exterior to the grinder. The standard pendant offers enable and direction control switches, a speed control potentiometer, and a digital RPM readout.

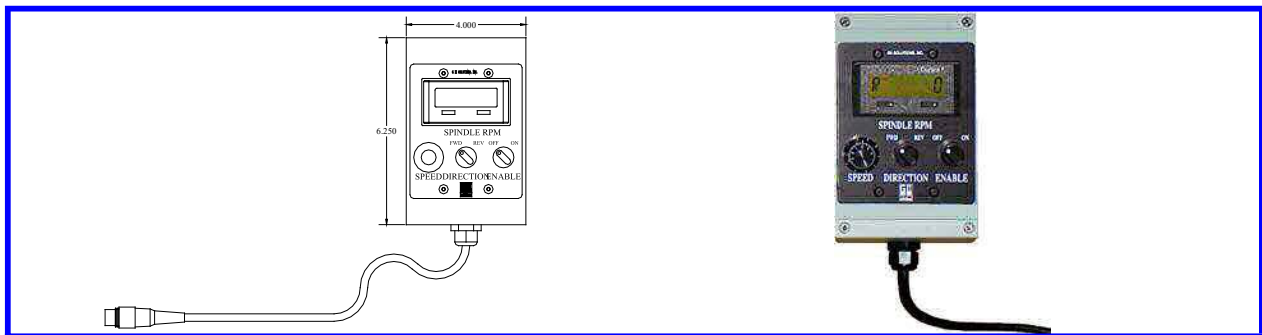

**G II Solutions, Inc.**  
 201 Bank Street  
 P.O. Box 428  
 Central, SC 29630

Phone: 864.639.6605  
 Fax: 864.639.4056  
 E-mail: [info@giisolutions.com](mailto:info@giisolutions.com)  
 Web Site: [www.giisolutions.com](http://www.giisolutions.com)

# Miscellaneous Options

Some grinding applications are able to utilize the standard system configuration and the options offered in this catalog up to this point. Most applications, since all are unique, inevitably will require additional special options. Shown on this page are various options that have been supplied in the past.

Extension Cable – This cable provides an extension between the bulkhead connector from the control panel or electrical enclosure and the spindle electrical connector.



Adapter Brackets – G II Solutions have developed numerous brackets for various grinder / spindle combinations. Oftentimes the more popular are in stock.



Diamond Rolls – Generally, G II Solutions will have some basic shaped diamond rolls in stock. If a particular style is not in stock, G II Solutions will help the customer find a solution.



Adapter Brackets – Most applications require a bracket to mount the spindle to the grinding machine. G II Solutions have developed various brackets for different spindle / grinder combinations. Often, G II Solutions will have the more popular combinations in stock. In any case, G II Solutions will work with the customer to identify, engineer, and if desired, manufacture the best solution.

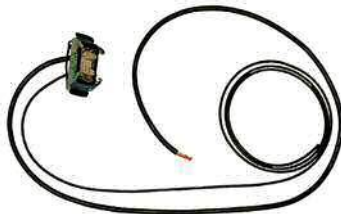

Interface Cable – This cable may be used as an interface between the external inputs and outputs of the control system and the interfacing machine's CNC and power.

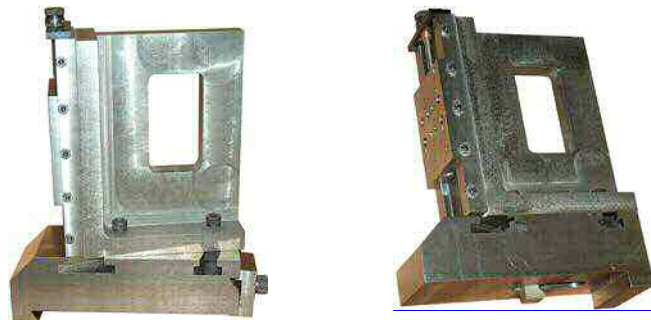

**G II Solutions, Inc.**  
201 Bank Street  
P.O. Box 428  
Central, SC 29630

Phone: 864.639.6605  
Fax: 864.639.4056  
E-mail: [info@giisolutions.com](mailto:info@giisolutions.com)  
Web Site: [www.giisolutions.com](http://www.giisolutions.com)

# SYSTEM SPECIFICATION WORKSHEET

SPINDLE:

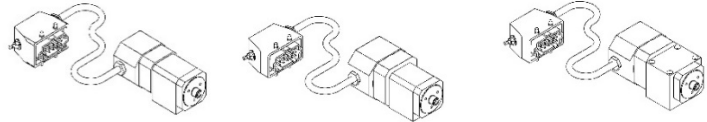

**DTS 1300    DTS 1350    DTS 1500**

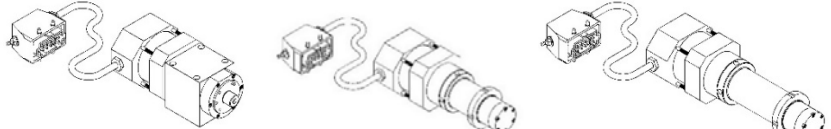

**DTS 3300    DTS 3402    DTS 3404**

CABLE EXIT DIRECTION:

SPINDLE CABLE LENGTH: (FT)

MOTOR CONTROL CABLE LENGTH: (FT)

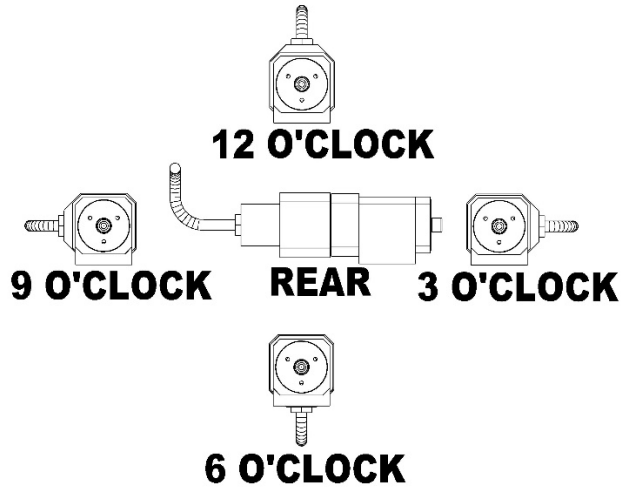

CONNECTOR:  
 BULKHEAD: (    )    SURFACE MOUNT: (    )



**BULKHEAD    SURFACE MOUNT**



G II Solutions, Inc.  
 201 Bank Street  
 P.O. Box 428  
 Central, SC 29630

Phone: 864.639.6605  
 Fax: 864.639.4056  
 E-mail: info@giisolutions.com  
 Web Site: www.giisolutions.com



# ELECTRICAL ENCLOSURE

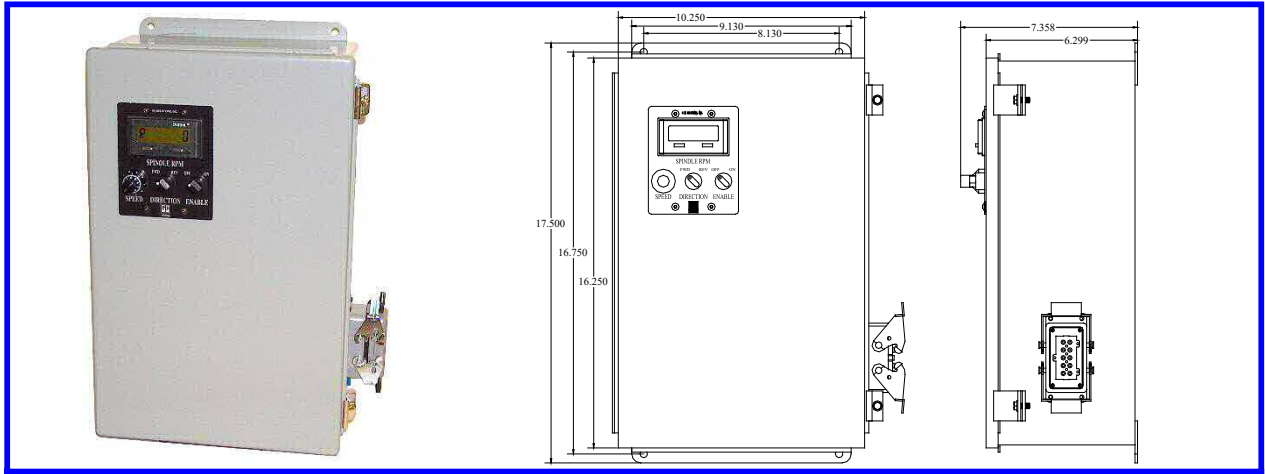

Electrical enclosure:

Manual control: Door:  In enclosure:

Motor control exit:

Bulkhead:  Cable:  Cable length:  feet.

Exit Location:

REMOTE PENDENT:

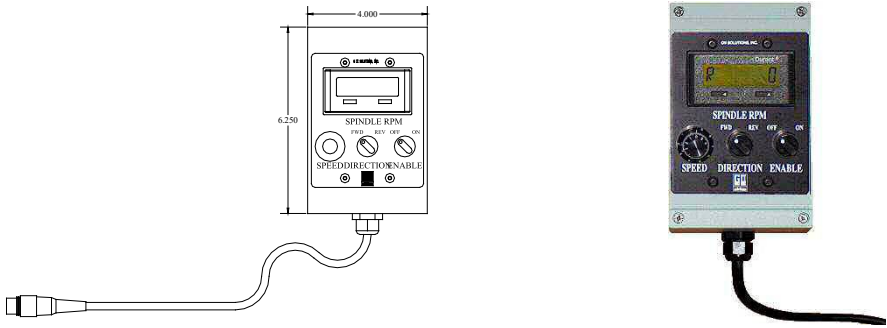

---

	<p><b>G II Solutions, Inc.</b>                  201 Bank Street                  P.O. Box 428                  Central, SC 29630</p>	<p>Phone: 864.639.6605                  Fax: 864.639.4056                  E-mail: info@giisolutions.com                  Web Site: www.giisolutions.com</p>
---	--	--

---

---

# Specifying DTS Systems

---

The following guidelines are offered for specifying DTS spindle systems:

1. Select a spindle model. Consult G II Solutions, Inc. when selecting the appropriate spindle model.
2. Determine a method to mount the spindle to the grinding machine. Most applications will require a custom interfacing bracket. G II Solutions, Inc. has developed numerous brackets for certain spindle/grinder combinations. Frequently, it is more efficient and less expensive for the customer to develop the interfacing bracket. Regardless, G II Solutions, Inc. will provide the necessary support for the customer to develop the interfacing bracket, or G II Solutions, Inc. will develop and manufacture the interfacing bracket.
3. Determine the orientation that the spindle cable exits the spindle (see page 12). The orientation is often determined after the method of mounting the spindle has been defined.
4. Determine a method to install the control system. With the standard system, the control panel is to be installed in the interfacing machine's electrical cabinet. If the electrical enclosure option is selected, determine where this enclosure is to be located.
5. Determine the length of the spindle cable and of the control panel cable (if applicable). The spindle cable exits the spindle and terminates at the spindle connector. The control panel cable exits the control panel and terminates at a bulkhead/surface-mount connector.

If the control panel is mounted in the interfacing machine's existing electrical cabinet, the bulkhead connector is generally mounted into the existing electrical cabinet wall. The control panel cable length should be determined to achieve this result. The spindle cable should then be sized so that the spindle connector reaches the bulkhead connector.

If the control panel is supplied in an electrical enclosure, then the spindle cable length should be sized so that the spindle connector reaches the bulkhead connector in the electrical enclosure.

6. The air purge unit comes with 10 feet of nylon tubing that terminates at a quick connect fitting that is to connect at the spindle connector. Factory air is to be supplied to the air purge unit.



**G II Solutions, Inc.**  
201 Bank Street  
P.O. Box 428  
Central, SC 29630

Phone: 864.639.6605  
Fax: 864.639.4056  
E-mail: [info@giisolutions.com](mailto:info@giisolutions.com)  
Web Site: [www.giisolutions.com](http://www.giisolutions.com)

---

---

# Observations & Precautions

---

1. Although the DTS spindles are compact units, they possess deceptively high power. The DTS spindles have considerably more power than most electrical spindles in their size range. Do not operate a spindle unless the spindle is properly secured. When activated, it can jump and cause damage to people and equipment.
2. DTS spindles operate under air purge. Therefore, it is acceptable to flood grinding machine coolant over the motor housing of the spindle. Consult factory if coolant pressure exceeds 60 psig.
3. The motors used in DTS spindles are high power brushless DC motors that operate with special electronic drives that provide commutation and speed control. Heat build up is one characteristic of these high torque motors. As a general rule, do not run the spindle if the motor is too hot to touch. The spindle should operate with a duty cycle with sufficient pauses to allow time for motor cooling. If no liquid coolant is used, the DTS spindle should only have a 25% duty cycle per any 30-minute period. If DTS spindles are used in a continuous operating mode, it is mandatory to spray coolant directly onto the motor housing. DTS spindles have an integrated temperature sensor to prevent over heating (the drive will shut down).
4. If the DTS spindle is mounted vertically, the air purge unit must be on at all times to prevent coolant from entering the spindle bearing housing.
5. The DTS spindles, although rugged, contain precision bearings. In the event of a crash, these bearings may be damaged, severely affecting the spindle runout.

---

# Rotary Dressing & Truing Tips

---

1. With rotary dressing and truing, heat is the enemy. If there is any visible light produced at the point of contact between the diamond roll and the grinding wheel, then too much heat is being generated. The result is the diamond is being burned away.
2. Rotary dressing and truing is not a bulk material removal process, but a repeatable method of controlling the form of a grinding wheel. Removal of too much material from the grinding wheel will result in excessive wear of the diamond roll. For cost effective grinding, the goal is to remove the minimum material to maintain the form of the wheel while producing the desired grit exposure.
3. Rotary dressing and truing is capable of producing a more open grinding wheel than single point dressing and truing and allows for more aggressive grinding.
4. In most dressing and truing operations, the DTS spindle and grinding wheel should move in the same direction at the point of contact, known as "unidirectional" dressing and truing. This means that from the same viewing perspective the wheels are rotating in opposite directions.
5. Establish an initial depth of cut per pass from .0005" for conventional grinding wheels and approximately 0.00005" for superabrasive grinding wheels.
6. Set the speed at which the dressing/truing roll travels across the grinding wheel to attain a 60% overlap ratio. In other words, any discrete point on the grinding wheel should move 40% of the way across the width of the diamond roll per grinding wheel revolution.
7. In the initial process development, set the truing spindle surface speed so that the surface speed of the diamond roll is:
  - 20% lower than the surface speed of a **diamond** grinding wheel,
  - 20% lower than the surface speed of a **CBN** grinding wheel,
  - 30% - 40% lower than surface speed of a **conventional** grinding wheel.These are all only a starting point. The process is significantly different from single point truing.



**G II Solutions, Inc.**  
201 Bank Street  
P.O. Box 428  
Central, SC 29630

Phone: 864.639.6605  
Fax: 864.639.4056  
E-mail: [info@giisolutions.com](mailto:info@giisolutions.com)  
Web Site: [www.giisolutions.com](http://www.giisolutions.com)

---

## DTS PERFORMANCE SPECIFICATIONS

DTS Model	No Load Speed	Operational Speed Range	Continuous Torque	Peak Torque	Continuous Power	Maximum Power	Approximate Size (L x W x H)
DTS 1300	12,000 RPM	1,000 RPM to 12,000 RPM	60 in-oz .42 N-m	310 in-oz 2.2 N-m	.30 HP .22 kW	.74 HP .55 kW	5.8" x 2.6" x 2.3"
DTS 1350	12,000 RPM	1,000 RPM to 12,000 RPM	100 in-oz .65 N-m	360 in-oz 2.5 N-m	.68 HP .50 kW	1.2 HP .9 kW	5.8" x 2.75" x 2.75"
DTS 1500							
DTS 3300	10,000 RPM	1,000 RPM to 10,000 RPM	270 in-oz 1.9 N-m	700 in-oz 5.0 N-m	1.6 HP 1.2 kW	2.03 HP 1.52 kW	8.3" x 3.9" x 3.6"
DTS 3402							10.0" x 3.9" x 3.4"
DTS 3404							12.0" x 3.9" x 3.4"

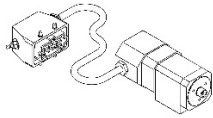

*DTS 1300*

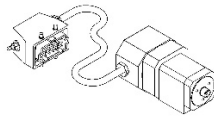

*DTS 1350*

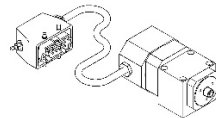

*DTS 1500*

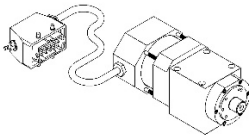

*DTS 3300*

### CANTILEVER MOUNT SPINDLE MODELS

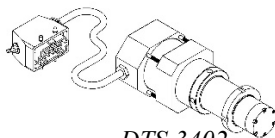

*DTS 3402*

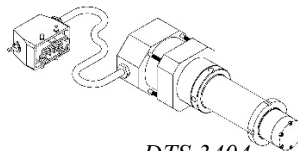

*DTS 3404*

### OUTBOARD SUPPORT SPINDLE MODELS



**G II Solutions, Inc.**  
201 Bank Street  
P.O. Box 428  
Central, SC 29630

Phone: 864.639.6605  
Fax: 864.639.4056  
E-mail: [info@giisolutions.com](mailto:info@giisolutions.com)  
Web Site: [www.giisolutions.com](http://www.giisolutions.com)